



### FEATURES

- DOUBLE UNION DESIGN PERMITS QUICK, EASY PIPING SYSTEM INSTALLATION, REMOVAL AND MAINTENANCE
- SAFETY DESIGN BLOW-OUT PROOF STEM
- MATERIAL AVAILABLE : PVC (OPTIONS CPVC, PP, PVDF)
- MATERIAL MEETS DRINKING STANDARD
- 100% PURE VIRGIN MATERIAL CACO3 FREE
- UV RESISTANT POWDER ADDED
- MAX. WORKING PRESSURE 150PSI
- MAX. TEMPERATURE PVC 55°C, CPVC 95°C
- CONNECTION STANDARD ANSI (OPTIONS DIN, JIS)
- SOCKET END (OPTIONS THREADED NPT, PT, BSP)
- SOLID SS CAST BRACKET ISO 5211 MOUNTING

### AUTOMA PNEUMATIC ACTUATOR

- SCOTCH YOKE DESIGN
- EXTRUDED ANODISED ALUMINUM
- DOUBLE COATED INTERNAL SURFACE
- ADJUSTABLE 5° OPEN/CLOSED POSITIONS
- DOME OPENING CLOSING INDICATOR
- NAMUR SOLENOID VALVE MOUNTING
- ISO5211 DIN 3337 VALVE MOUNTING

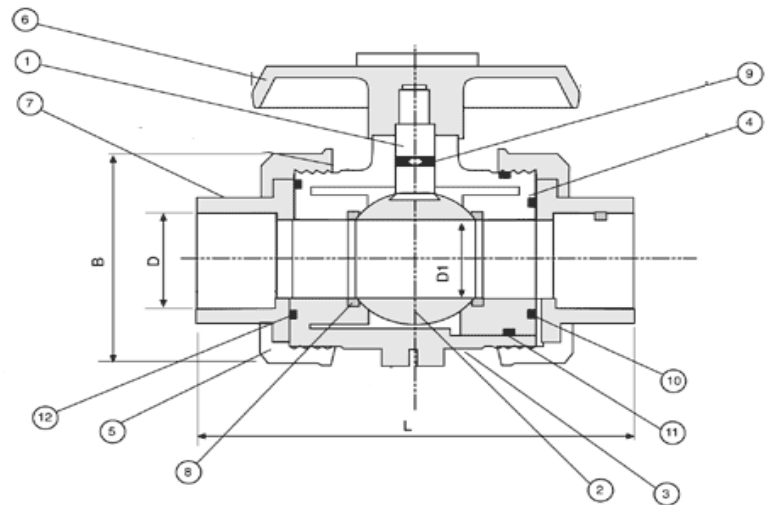
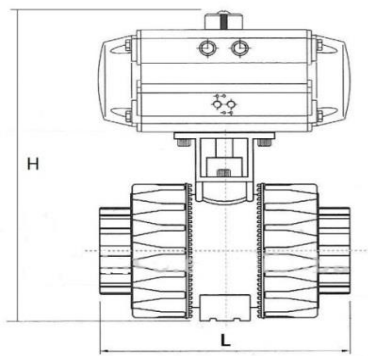

### MATERIAL LIST

NO.	PART NAME	MATERIAL
1	Stem	PVC/CPVC
2	Ball	PVC/CPVC
3	Body	PVC/CPVC
4	Seat Carrier	PVC/CPVC
5	Union nut	PVC/CPVC
6	Handle	UPVC/CPVC
7	End connector	PVC/CPVC
8	Seat	TEFLON
9	Stem O-ring	EPDM
10	Seat Carrier O-ring	EPDM
11	Body end O-ring	EPDM
12	Solid end O-ring	EPDM

### DIMENSIONS ANSI

SIZE		D	B	L	H*
INCH	D1				
1/2"	15	21.2	54.0	104.8	159.0
3/4"	20	26.6	63.0	113.0	168.0
1"	25	33.3	73.5	127.2	178.5 / 202.5
1-1/4"	32	42.0	84.5	142.0	217.5
1-1/2"	40	48.1	98.0	157.5	231.0
2"	50	60.2	118.0	171.0	261.0
2-1/2"	63	72.9	150.0	238.5	295 / 312
3"	75	88.7	169.0	268.0	314 / 331

\* Dimension in double acting / spring return

We reserve the right to change product design and technical dimensional specifications without notice!