

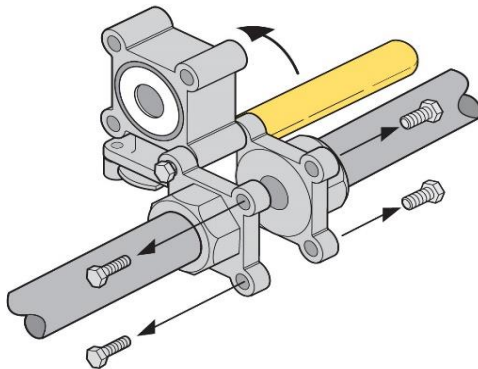

AUTOMA 3-piece body spring check valve allows easy maintenance of repair kit without removing end caps from pipe line. The body is made of investment casting and the valve is suitable for Food Industries, Palm Oil and Refinery, Rubber Glove, Power, Oil and Gas, Petrochemical Industries and Genral Industrial Plants.

**SPECIFICATION:**

- Investment casting body CF8M
- Valve can be installed vertically or horizontally
- Maximum working pressure: 40bar
- Temperature range: -10 to +180° C



3-piece body allows for withdrawal of valve body for easy maintenance service

**PRESSURE TEST**

| BODY                  | SEAT                  |                      |
|-----------------------|-----------------------|----------------------|
|                       | by water              | by air               |
| 60 kg/cm <sup>2</sup> | 40 kg/cm <sup>2</sup> | 6 kg/cm <sup>2</sup> |

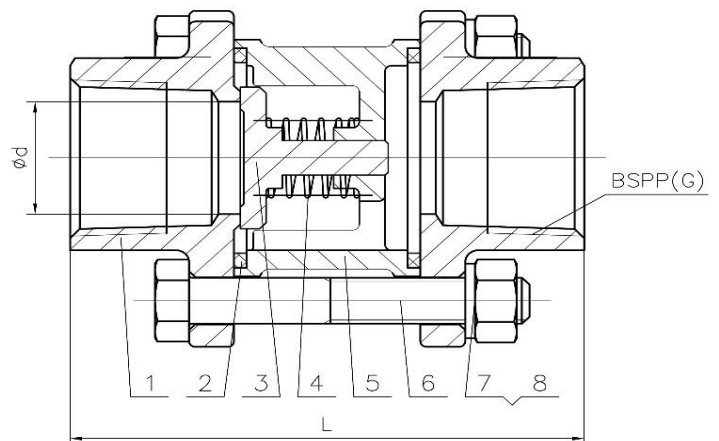
**DIMENSIONS**

| SIZE |       | d  | L   |  |  |
|------|-------|----|-----|--|--|
| DN   | G     |    |     |  |  |
| 15   | 1/2   | 14 | 75  |  |  |
| 20   | 3/4   | 19 | 80  |  |  |
| 25   | 1     | 24 | 86  |  |  |
| 32   | 1-1/4 | 31 | 104 |  |  |
| 40   | 1-1/2 | 39 | 115 |  |  |
| 50   | 2     | 49 | 122 |  |  |

**MATERIAL LIST**

| NO. | PART NAME | MATERIAL |
|-----|-----------|----------|
| 1   | Cap       | CF8M     |
| 2   | Gasket    | PTFE     |
| 3   | Disc      | CF8M     |
| 4   | Spring    | SS316    |
| 5   | Body      | CF8M     |
| 6   | Bolt      | A193-B8  |
| 7   | Washer    | A140     |
| 8   | Nut       | A194-8   |

The specification and dimensions are subject to change without prior notice!